

# Mystic West Banjo Silencer™

## Instruction Sheet

### Reference Diagram

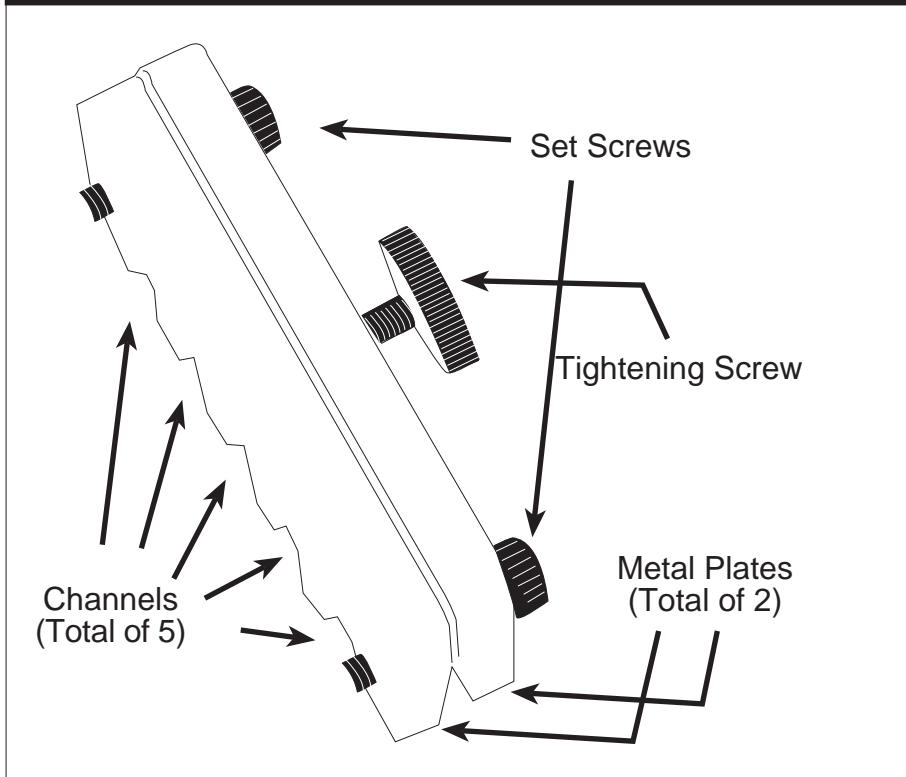

Images and Text Copyright ©2004 by Mystic West

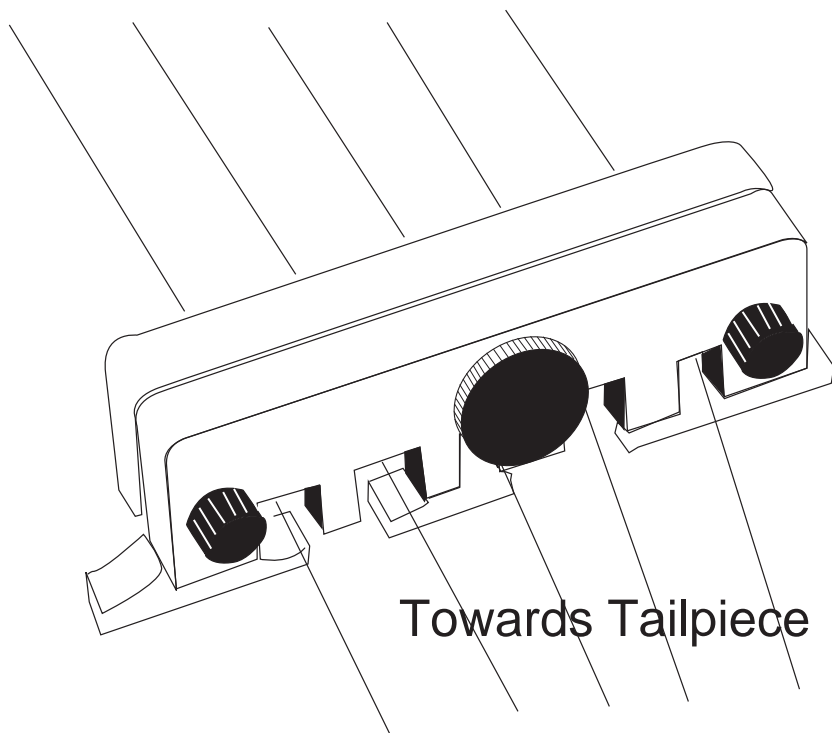

1. Place Silencer on table face up...compare diagram to the left with your new silencer to learn names of all parts.

2. Loosen the Set Screws so that there's a nice gap between the two metal plates. Make sure that the Tightening Screw is also loose. Do not remove any screws; the screws should still be in place before proceeding.

3. Place your banjo on a flat surface making sure the area is cleaned up well to prevent damage or scratches to the back of your banjo.

4. Carefully place Silencer over the top of the banjo bridge making sure that the Screw Adjustment Heads are facing towards the tailpiece and each string is centered within its respective channel.

5. Let the Silencer go all the way down on the top of the bridge until the set screws, in between both metal plates, are resting on its top.

6. Now hand-tighten both set screws until the metal plates are tightly adjusted against the bridge.

7. The final adjustment, to ensure proper tightness over the bridge, requires that the tightening screw is hand-tightened as tight as possible. Do not store the Silencer in your case while mounted to your banjo.

8. To ensure the Banjo Silencer is properly fitted, try pulling up on it. If the Silencer is loose in any way, repeat the above instructions.

9. After ensuring that the Banjo Silencer is properly fitted, you're now ready to pick up your banjo and play.

10. Be aware, although the profile is lower than the average banjo mute, you may find that the Silencer will get in your way when playing near the bridge. It's highly recommended to move your hand position towards the fingerboard for an even softer sound and more sustain.

**Disclaimer:** Mystic West, and its representatives, do not hold responsibility in any way or form if damage or injury occurs during operation and use of the Banjo Silencer. Please be extra careful in the use and operation of this piece of equipment. By following the above directions carefully, and ensuring that your Silencer is properly installed, and tightly fitted, it is unlikely that you should encounter a problem. Nevertheless, you'll always want to be extremely careful by double and triple-checking for a tight fit on your banjo bridge. The Banjo Silencer is not intended to be used in any other manner than specified above.